

A.) Checking Index Output Shaft Backlash

- 1.) Place a dial indicator on the output shaft dial, rotate the dial with your hands or short bar in 1 direction and remove your hands from the output shaft dial. Zero the dial indicator and rotate the output shaft dial in the opposite direction and release your hands and record the dial indicator reading. Standard index units should be equal or less than ± 0.00015 inches per every inch of radius from the center of the output flange or output shaft. Example: standard ± 30 arc second accuracy index with a 24-inch diameter dial (12-inch radius), the backlash should be ± 0.00175 inches.
- 2.) While the above procedures are being performed, locate another dial indicator on the end (not the side) of the index input shaft to check right to left motion (end play). This procedure will check the input shaft bearing pre-load. Standard index units should be 0 to 0.0002 inches depending on the size of the index.

B.) Setup Of The Timing Sensor Cam Shutter

- 1.) The input shaft and output shaft are 1 to 1 ratio on a single dwell cam (usually 16 or less output positions). A 2-dwell cam has 1 output shaft position change to a half rotation of the input shaft (usually 16 to 32 output positions). A 3 dwell is 3:1 ratio and 4 dwell is 4:1 ratio. The open section of the cam (shutter) or when the sensor beam is not broken should occur when the index is in the dwell position (see: Verifying the index motor is stopping in the dwell period section).
- 2.) Adjust the timing cam (shutter) with open area in the sensor path during the index dwell period; the sensor beam should not be broken during the index dwell period. During the cam index period, the output shaft rotates; the motor should always be stopped in the dwell period. Note, if the input shaft RPM is very fast or if the output shaft torque is enough to back drive the index, the timing cam may require adjustment. In such cases, additional braking capacity is required, usually by using a braking resistor on the variable frequency drive

C.) Verifying The Index Motor Is Stopping In The Dwell Period

- 1.) After the controller stops the index, turn off power & rotate the index drive motor by inserting a hex wrench (or screwdriver) through the center of the fan cover on the rear of the motor. While rotating in the same direction, count the wrench rotations until the output shaft (dial) starts to rotate. A dial indicator mounted on the output shaft may be helpful to determine when the shaft starts to rotate.
- 2.) Count the wrench rotations in the opposite direction until the output shaft starts to rotate in the opposite direction, this count will represent the full dwell period. Ideally, the motor should stop in the middle of the dwell period.

D.) Delta VFD Series-S Key Stroke Setup (Standard Alpha Series Index Motor Controller)

- 1.) After power up, the LED displays: F60.0, this is the motor speed or frequency, change the frequency to the desired speed using the up-down arrows & press the “Prog Data” button to save the setting, the “Prog Data” button serves as enter-save functions.
 - 60 Hz is equal to the full speed of the motor, usually 1800 rpm
 - Set the frequency to 20 ~ 120 Hz on inverter rated motors, Alpha series 7AD & 23AD
 - Set the frequency to 39 ~ 72 Hz on non-inverter rated motors, Alpha series, 9AD, 11AD & 15AD
- 2.) The LED displays: 0-, select the parameter section (0 thru 9) using the up-down arrows & press the “Prog Data” button.
- 3.) The LED displays: 0-00, select the parameter (0 thru 18) using the up-down arrows & press the “Prog Data” button.
- 4.) The LED displays: d-4, select the option (d-0 thru d-21) using the up-down arrows & press the “Prog Data” button.
- 5.) Press the “Mode” button to return to the previous screen, the “Mode” button serves as scroll-back functions.

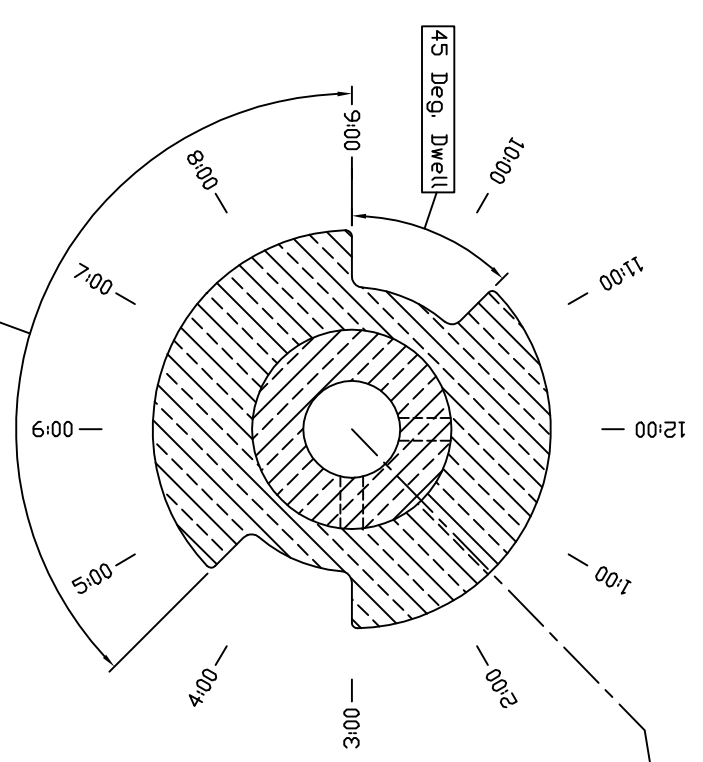
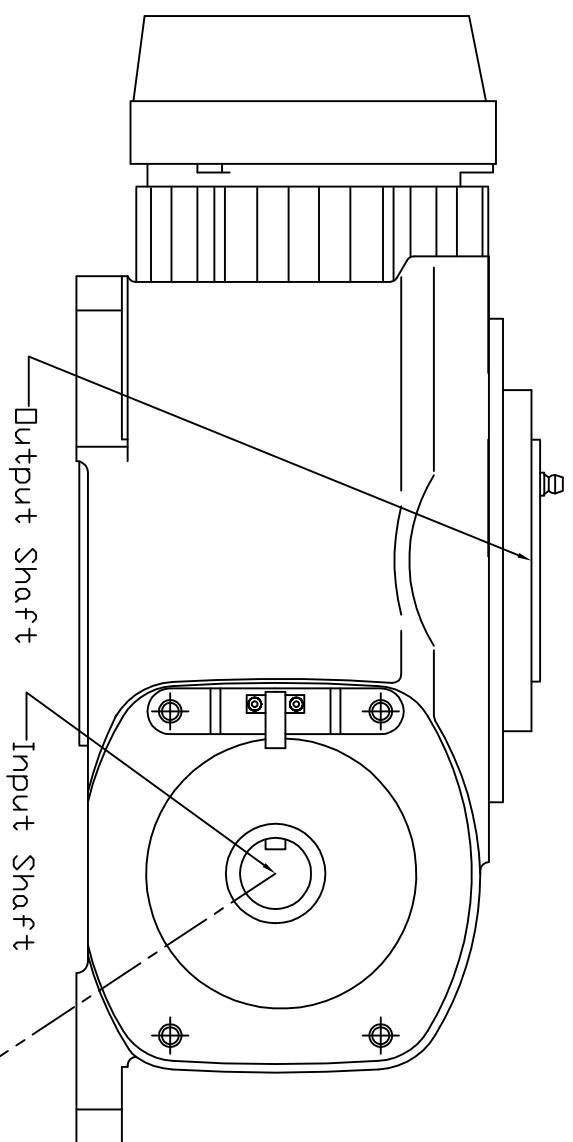

Index Period (sensor beam broken with output rotation)
 270° INDEX PERIOD, 2 DWELL

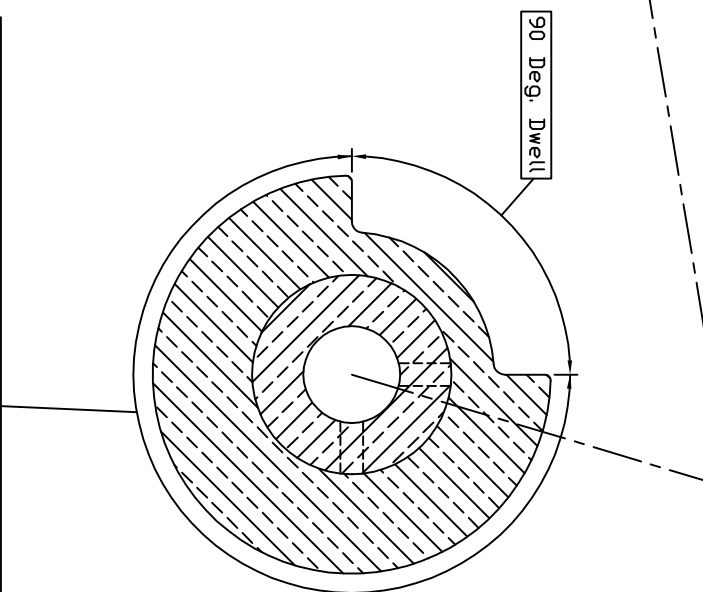

Index Period (sensor beam broken with output rotation)
 270° INDEX PERIOD, 1 DWELL