

# PRODUCT SPECIFICATION

## 7ED

(Unit : mm)

### 7ED Dimensions

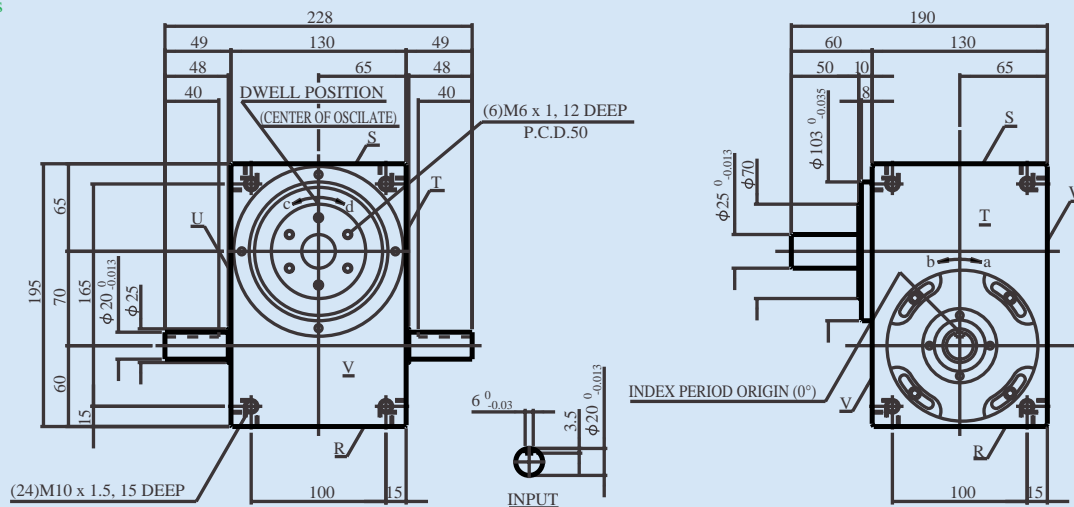

Figure 7ED-1

Dynamic-rated output torque (Top) at 50ipm(N·m)

Table 7ED-1

S	$\theta$	90°	120°	150°	180°	210°	240°	270°	300°	330°
2								42.4	42.5	42.4
3					50.9	59.0	58.7	58.2	57.6	57.0
4			19.2	19.2	56.1	55.5	54.7	53.8	52.9	52.0
6		80.6	80.2	78.7	76.9	75.0	73.1	71.3	69.6	68.0
8		68.0	72.2	72.3	78.5	76.0	73.7	71.6	69.7	67.9
12		15.6	14.8	14.1	13.4	12.9	12.5	12.1	11.7	11.4

$\theta$ :Index period S:Number of Stops Note:Cam curve is SMS-3 curve.

Note:

- Torque limiter 6TF,6TC,7TF or 7TC available for 7ED
- Spacer required to mount torque limiter
- Output shaft available to shorten to 10mm height
- Geared motor (0.2kW) is available for 7ED
- Rated output torque (Top) is a maximum continuous torque allowed based upon 12,000 hours of endurance life

## 8ED

(Unit : mm)

### 8ED Dimensions

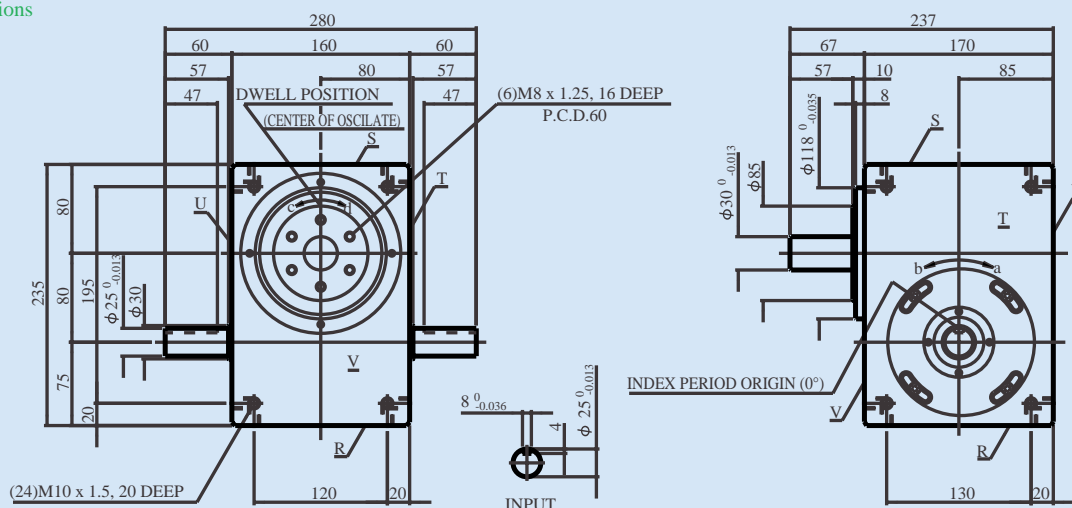

Figure 8ED-1

Dynamic-rated output torque (Top) at 50ipm(N·m)

Table 8ED-1

S	$\theta$	90°	120°	150°	180°	210°	240°	270°	300°	330°
2								77.0	77.1	77.0
3					92.4	92.5	92.1	91.5	90.7	89.7
4			30.6	74.4	99.3	98.3	97.0	95.6	94.1	92.5
6		126.2	196.4	193.3	189.1	184.6	180.1	175.8	171.7	167.9
8		111.3	116.4	120.7	143.8	139.2	135.0	131.3	127.8	124.7
12		85.1	88.3	90.1	91.1	91.7	92.1	92.4	92.7	92.8

$\theta$ :Index period S:Number of Stops Note:Cam curve is SMS-3 curve.

Note:

- Torque limiter 7TF, 7TC, 8TF or 8TC available for 8ED
- Spacer required to mount torque limiter
- Output shaft available to shorten to 10mm height
- Geared motor (0.4kW) is available for 8ED
- Rated output torque (Top) is a maximum continuous torque allowed based upon 12,000 hours of endurance life